

IRONCLAD SPORTS, INC TRIPLE THREAT

ADJUSTABLE BASKETBALL SYSTEM ASSEMBLY INSTRUCTIONS AND OWNER'S MANUAL

**MODEL: TPT-443
TPT-553
TPT-554**

⚠ WARNING ⚠

FAILURE TO COMPLY WITH ANY OF THE WARNINGS IN THESE INSTRUCTIONS MAY RESULT IN SERIOUS PERSONAL INJURY.

FAILURE TO COMPLY MAY ALSO RESULT IN PROPERTY DAMAGE. PLEASE HEED ALL WARNINGS AND CAUTIONS TO ENSURE YOUR SAFETY.

DO NOT ATTEMPT TO ASSEMBLE THIS SYSTEM WITHOUT CAREFULLY READING AND FOLLOWING ALL INSTRUCTIONS. BEGIN BY IDENTIFYING AND TAKING INVENTORY OF ALL PARTS USING THE PARTS LIST PROVIDED.

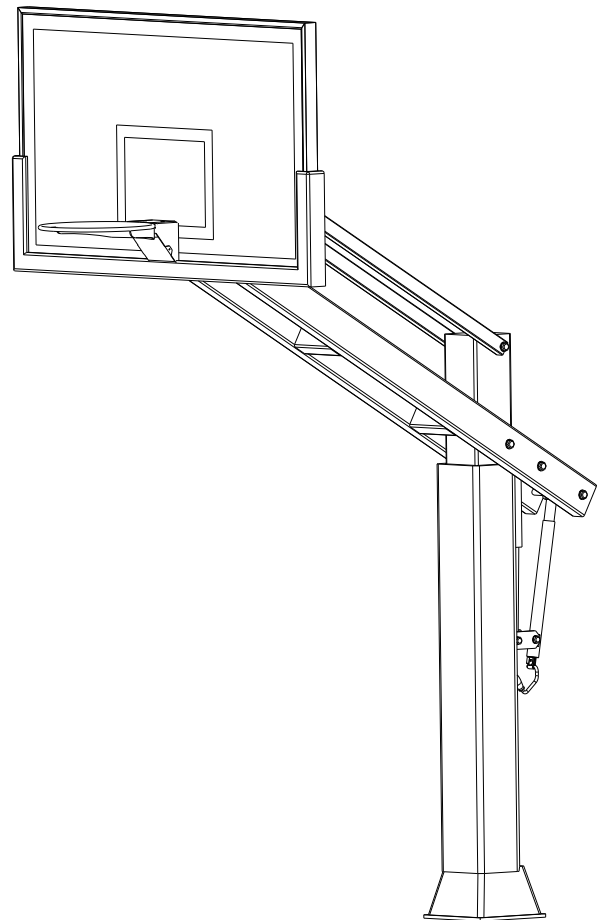

IRONCLAD SPORTS, INC
902 Corey Road, Hutchinson, KS 67501
Toll Free: 888-662-2233
www.ironcladsports.com

Keep this instruction manual in case you have to contact the manufacturer for replacement parts.

TOOLS AND MATERIALS REQUIRED FOR ASSEMBLY
(Not Included)

- | | |
|--------------------------|---|
| 1. 2 Adjustable Wrenches | 10. Concrete-1/2 yard or 14-16
Bags, (80 lb. bags) |
| 2. Socket Set | 11. Phillips Head Screwdriver |
| 3. 9/16" Wrench | 12. Electric Drill |
| 4. 3/4" Wrench | 13. Carpenter's Level |
| 5. 15/16" Wrench | 14. A minimum of 2 Ladders |
| 6. 1/2" Wrench | 15. Water Supply |
| 7. Hammer or Mallet | 16. Degreaser |
| 8. Tape Measure | 17. 1/4" Drill Bit |
| 9. Shovel | |

**** A MINIMUM OF SIX ADULTS IS
REQUIRED TO LIFT UNIT INTO PLACE ****

STOP!

BEFORE YOU START

STOP!

- A. Identify and inventory all parts using the checklist boxes in the parts list. Be sure to keep the hardware bags and their contents separate. If any parts are missing call our Customer Service Department (888-662-2233).
- B. Test fit all Bolts by inserting them into the respective hole. If necessary, carefully scrape away any excess powder coating buildup from inside the holes. Do not scrape away all of the powder coating. Bare metal may rust.



SAFETY INSTRUCTIONS



FAILURE TO FOLLOW THESE SAFETY INSTRUCTIONS MAY RESULT IN SERIOUS INJURY OR PROPERTY DAMAGE AND WILL VOID THE WARRANTY. The owner must ensure that all players know and follow these rules to safely operate the system. Proper and complete assembly, use and supervision is essential for proper operation and to reduce the risk of accident or injury. A high probability of serious injury exists if this system is not installed, maintained, or operated properly.

- If using a ladder during assembly, use extreme caution. Follow all warnings and cautions on the ladder carefully.
- 6 people are required to lift the unit into place.
- Before digging, contact the appropriate agency to locate underground power cables, gas, and water lines. Do not install the system within 20 feet of overhead power lines.
- Climate, corrosion, or misuse could result in system failure.
- If technical assistance is required, contact the manufacturer.
- Minimum operational height is 7' 6" to the Rim. Most injuries are caused by misuse and/or failure to follow instructions. Use caution when using the system.

PARTS LIST

Verify all parts listed on packing list are present prior to installation. Contact our Customer Service at 888-662-2233 for assistance with replacement of any parts missing or damaged.

TEM	QTY	DESCRIPTION
A	1	Main Post
B	1	Main Extension Arm
C	2	Upper Extension Arms
D	1	H-Frame Backboard Mount
E	1	Spring-Assist Cartridge
F	1	Actuator-Height Adjustment Device
G	1	Rim Height Indicator
H	1	Rim Height Sticker
I	2	14mm x 12cm Hex Bolts
J	2	14mm Lock Nuts
K	4	16mm x 29cm Hex Bolts
L	2	16mm x 26cm Hex Bolts
M	6	16mm Lock Nuts
N	4	16mm Anchor J-Bolts
O	1	Anchor Template
P	4	Anchor Rebars
Q	8	Thick Washers
R	8	16mm J-Bolt Hex Nuts
S	4	16mm Flange Nuts
T	4	14mm Flat Washers
U	12	16mm Flat Washers
V	4	Plastic and steel Spacers

NOTE: Before digging, call to locate any buried utility lines.

NOTE: At rim height 10', distance from the face of backboard to the front of Main Post(A) is as below, Choose the proper location to dig for the concrete footing:

TPT-443 = 36"

TPT-553 = 36"

TPT-554 = 48"

- a. Dig a hole 48" deep and 21"x21" square. The edge of the hole should be flush with the edge of the playing surface. If you live in an area where heavy frost can occur, it may pose a problem, consult your local building inspector to determine the appropriate hole depth.

NOTE: The hole must be at least 48" deep.

- b. Build a form before pouring the concrete pad, to ensure that the top of the concrete remains straight and square. The form should be placed about 1/2" above the playing surface to allow for water drainage.
- c. Bell out the bottom of the hole.

NOTE: A square hole prevents the rotation of the concrete.

NOTE: The area behind the playing surface must be cleared off by at least 3 feet to enable the user to stand behind the pole to adjust the Rim height.

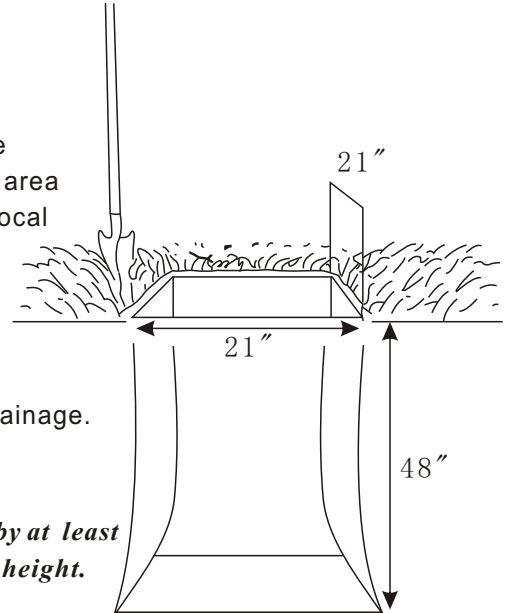

STEP B

- A. Thread a 16mm Hex Nut (M) onto each of the 16mm J-Bolts (N). Securely tighten the Nuts all the way down to the end of the threads.
- B. Slide the threaded end of the J-Bolts through the holes in the Anchor Template (O) and secure each J-Bolt with a 16mm J-Bolt Hex Nuts (R) as shown. Securely tighten all Nuts at this time.

NOTE: Make sure the curved "J" ends of the J-Bolts are oriented in a rectangular pattern, as shown.

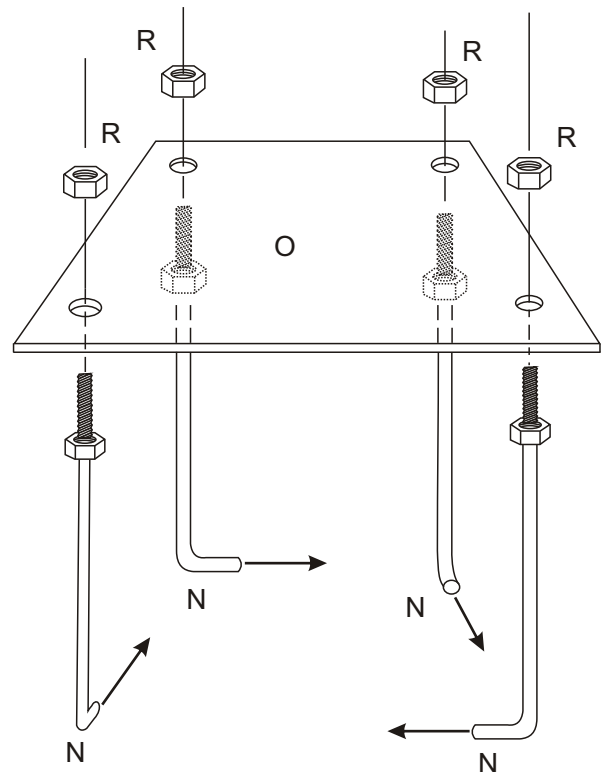
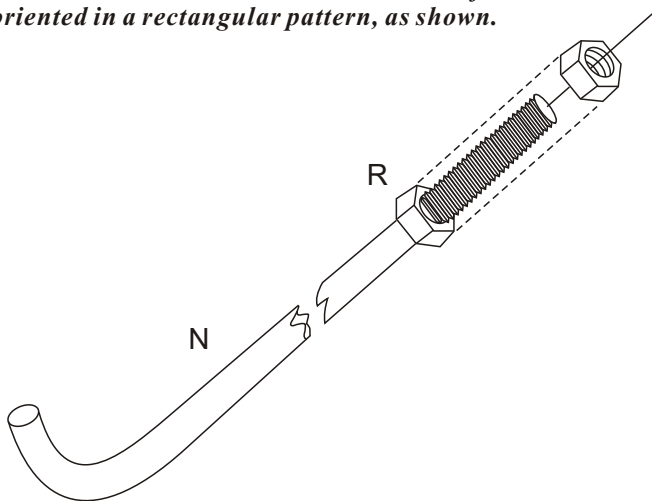

STEP C

- Mix the concrete according to the instructions on the bags. Note that a thicker mix of concrete will dry stronger than a thin mix. Pour the concrete into the hole, stopping approximately 18 inches from the top of the hole.
- Insert the four pieces of Anchor Rebar (P) into the hole, pushing each piece firmly to the bottom of the hole. The four pieces should be arranged in a square approximately 8 inches wide so that each piece of rebar will be positioned next to the J-Bolts when the J-Bolt Template is placed in the cement.
- Finish filling the hole to the top with concrete. The top of the concrete should reach just above the level of the top of the form.

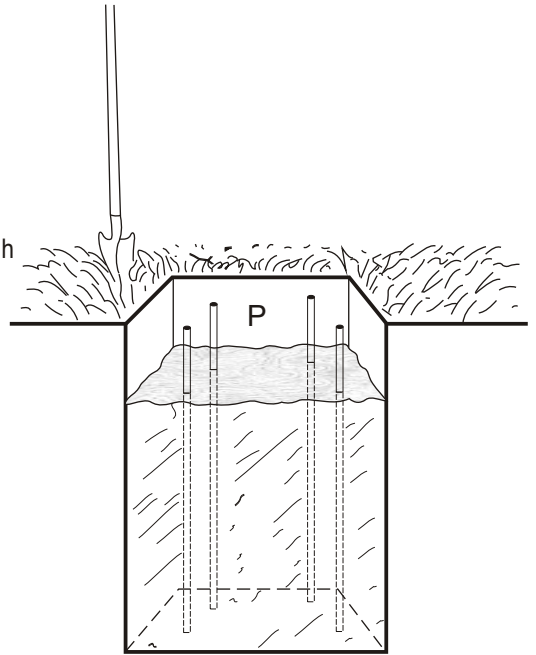

STEP D

- Position the J-Bolt Template (O) over the hole so that it is centered, with the sides of the plate square with the sides of the hole.
- Push the J-Bolts (N) into the concrete until the J-Bolt Template is resting flat against the surface of the concrete.
- Grasp the tops of the J-Bolts and agitate the Template assembly back and forth repeatedly to eliminate any air bubbles in the concrete. Lift the Template slightly above the concrete when agitating. Make sure the Template is resting on the concrete after agitating. Form the concrete into a downward slope away from the Pole to allow water runoff.
- Clean off any concrete that may be on the J-Bolt Template or the exposed portions of the J-Bolts.
- Using a carpenter's level, make sure the Template is square to and level with the playing surface.
- Allow the concrete to cure for a **minimum** of 5-7 days before installing the rest of your basketball system. In cold, wet weather or humid climates, allow additional time for the concrete to cure.

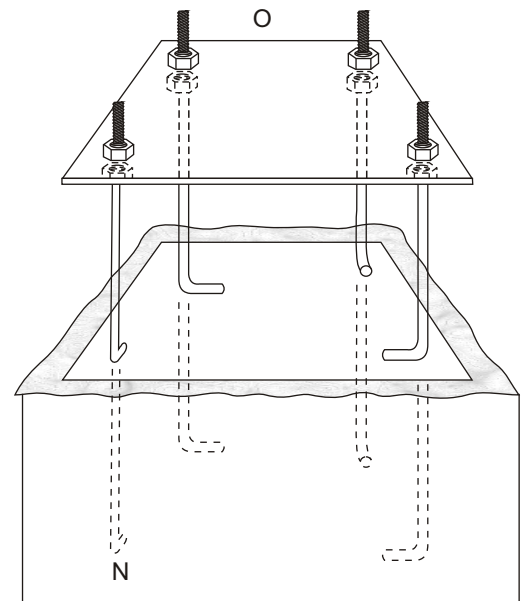

YOU ARE NOW FINISHED WITH THE INITIAL ASSEMBLY STEPS. DO NOT PROCEED WITH THE ASSEMBLY UNTIL THE CONCRETE HAS FULLY CURED. CURING WILL TAKE A MINIMUM OF 72 HOURS. IN HUMID CLIMATES OR WET WEATHER, ALLOW ADDITIONAL TIME FOR THE CONCRETE TO CURE.



WARNING



NEVER USE THE SYSTEM WITHOUT FOLLOWING THE CEMENTING INSTRUCTIONS. FAILURE TO FOLLOW ALL OF THESE INSTRUCTIONS AND WARNINGS COULD LEAD TO SERIOUS PERSONAL INJURY OR PROPERTY DAMAGE AS LISTED ON PAGE ONE.



WARNING



BECAUSE OF THE SIZE AND WEIGHT OF THE SYSTEM, A MINIMUM OF THREE ADULTS ARE REQUIRED FOR THE FOLLOWING STEPS

STEP 1

- A. Slide a 16mm Thick Washer (Q) over each of the J-Bolts(N) as shown in FIGURE 1A.
- B. Place the Main Post(A) over the J-Bolts. Slide a 16mm Thick Washer(Q) and thread a 16mm Flange Nut(S) to each J-bolt. Tighten the Nuts only a few turns onto the J-Bolts as shown in FIGURE 1B.
- C. If the Main Post (A) is not exactly vertical, adjust the 16mm J-Bolt Hex Nuts(R) located under the Post base. Tighten all of the Flange Nuts(S) when Main Post(A) is vertical.

NOTE: Face the Main Post(A) with Actuator Bracket facing away from playing court(as shown in FIGURE 1C).

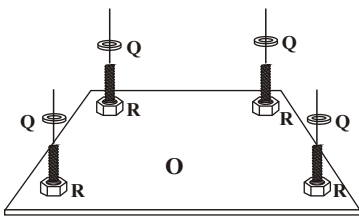

FIGURE 1A

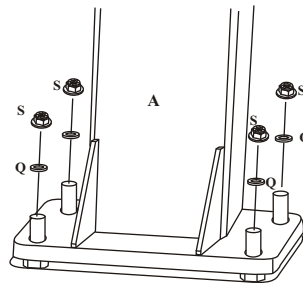

FIGURE 1B

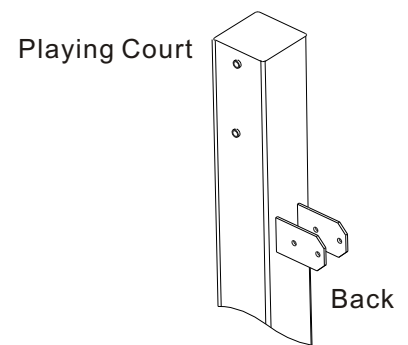
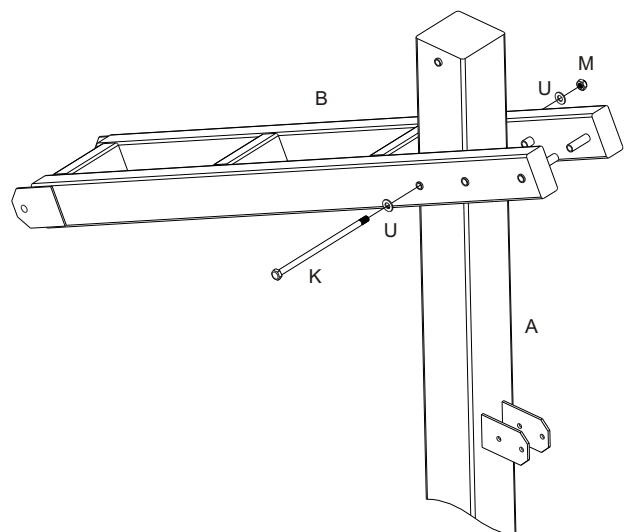

FIGURE 1C

STEP 2

- A. Slide the Main Extension Arm(B) over the top of the Main Post(A) and attach to the lower pivot tube with a 16mm x 29cm Hex Bolt(K), two 16mm Flat Washers(U) and a 16mm Lock Nut(M).



STEP 3

- A. Slide the Actuator(F) to the last set of welded tubes on the Main Extension Arm(B), Using a 16mm x 29cm Hex Bolt(K), two 16mm Flat Washers(U) and a 16mm Lock Nut(M) at the top. And using a 14mm x 12cm Hex Bolt(I), two 14mm Flat Washer(T) a 14mm Lock Nut(J) on bottom to tight the Actuator.

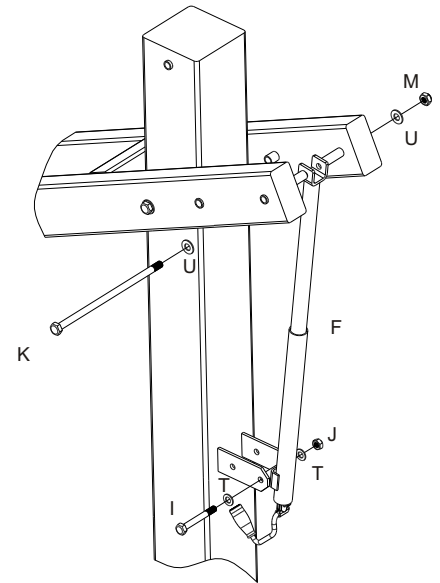

STEP 4

- A. Attach the Plastic Rim Height Indicator(G) and the Spring-assist Cartridge(E) to the second set of welded tubes on the Main Extension Arm(B) by using a 16mm x 29cm Hex Bolt(K), two 16mm Flat Washers(U) and a 16mm Lock Nut(M). The Plastic Rim Height Indicator(G) should hang freely along side the Spring-Assist Cartridge(E).
- B. Attach the bottom of Spring-assist Cartridge(E) to the welded Actuator Bracket by using a 14mm x 12cm Hex Bolt(I), two 14mm Flat Washers(T) and a 14mm Lock Nut(J).
- C. Remove and discard the blue plastic spreader tube from the Spring-Assist Cartridge(E).

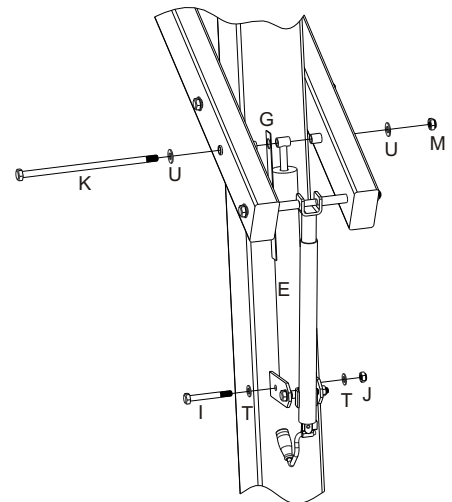

STEP 5

- A. Attach the 2 Upper Extension Arms(C) to Main Post(A) with a 16mm x 26cm Hex Bolt(L), two 16mm Flat Washers(U) and a 16mm Lock Nut(M).

NOTE: It does not matter which end of the Upper Extension Arms you attach to the Main Post(A).

CAUTION: Injury may occur if Upper Extension Arms are allowed to fall off Main Extension Arm during assembly.

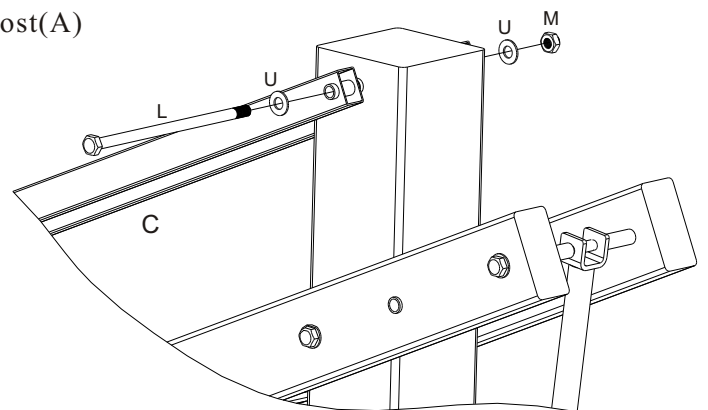

STEP 6

A. Attach the backboard to Main Extension Arm(B) by using a 16mm x 29cm Hex Bolt(K), two 16mm Flat Washers(U) and a 16mm Lock Nut(M). And then secure the Upper Extension Arm(C) to Backboard by using a 16mm x 26cm Hex Bolt(L), two 16mm Flat Washers(U) and a 16mm Lock Nut(M).

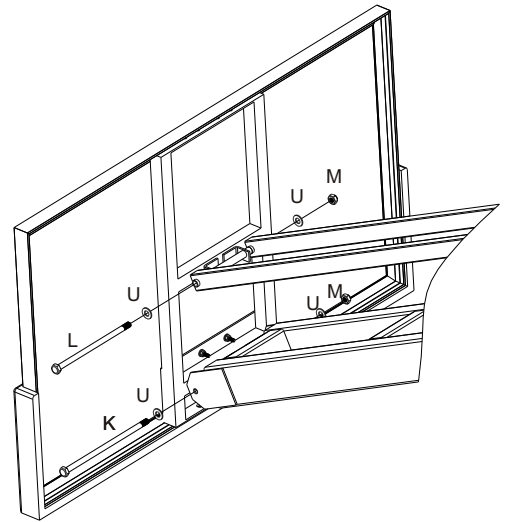

STEP 7

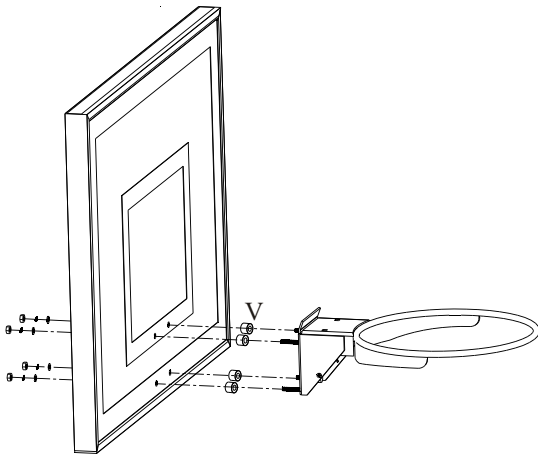

A. Insert the 4 Plastic and Steel Spacers(V) into the 4 holes on the backboard.

CAUTION: Do not proceed with rim installation without these spacers!

B. Mount the rim to the H-frame Backboard Mount(D) and Backboard Assembly using the hardware supplied in rim box.

NOTE: Use a level to make sure rim is level side to side before tightening nuts.

STEP 8

A. After everything is square, make sure all nuts on the system have been tightened.

NOTE: But do not over tighten the Nuts, make sure the unit can be adjusted up and down.

B. To apply the Rim Height Sticker(H), first use a tape measure to crank rim up to exactly 10' from the playing surface. Use a pencil to make a mark on the Spring-assist Cartridge(E) where the bottom of the Rim Height Indicator(G) stops. Then, peel and apply Rim Height Sticker(H) to outside of Spring-assist Cartridge(E) lining up the pencil mark with the 10' mark on the Rim Height Sticker(H).

C. Attach Post Pad and Gusset Pad to Main Post(A) as shown.

